

Casket Lift Design Guide

ASME B20.1

For Models:

1320 [Single Mast VRC]

1520 [Telescopic Mast VRC]

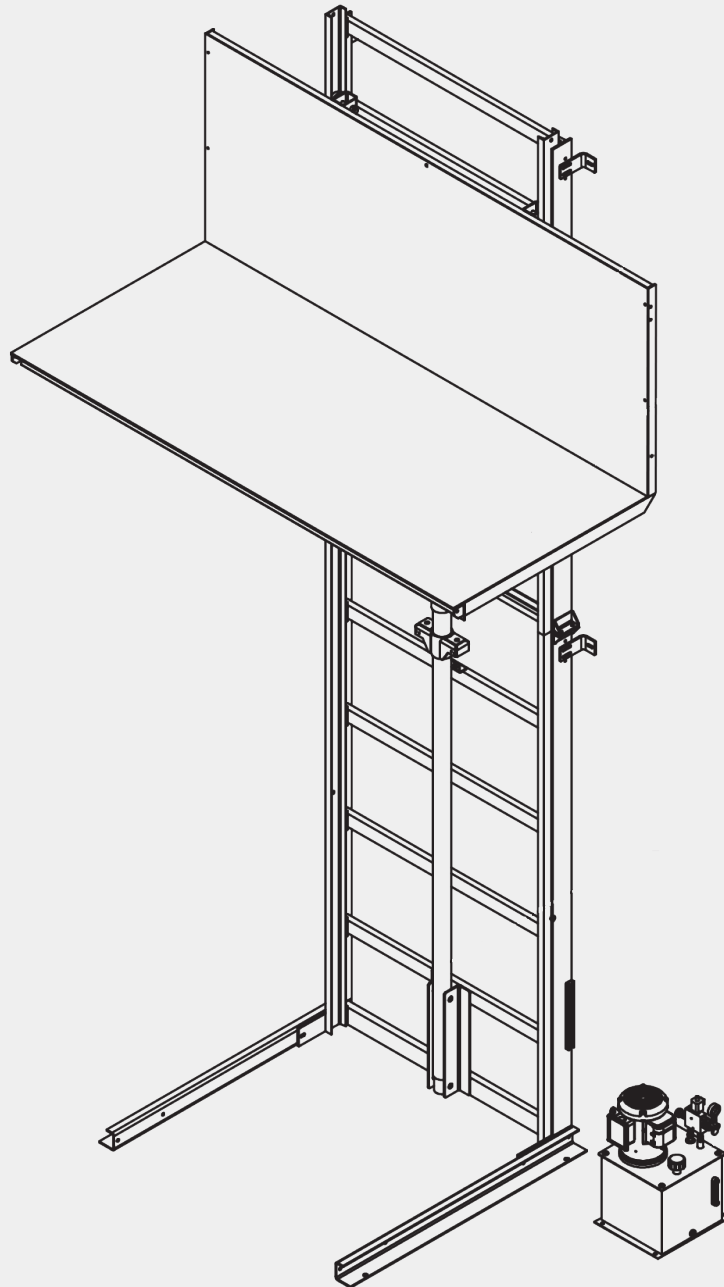

Table of Contents

About Symmetry Elevating Solutions	2
What is a Casket Lift?	3
Component Identification	4
Upper Landing Guarding	5
Common Specifications	6
Applications	7
Loading Configurations	8-9
Shaftway Configurations	10-12
Enclosure Configurations	12-13
Anchorage	14
Lower Landing Platform Access	15
Overhead	16
Doors and Gates	17
Platform Guarding Options	18
Hydraulic Power Unit/Control Stations	19

About Symmetry Elevating Solutions

Symmetry is a beautifully crafted, expertly engineered accessibility-related product line proudly **made in the U.S.A.** at the Bella Elevator LLC manufacturing plant. Promoted and sold by our exclusive nationwide network of carefully selected Symmetry partners and associates, Symmetry offers residential elevators, vertical platform lifts (VPL), limited use/limited application (LU/LA) elevators and vertical reciprocating conveyors (VRC).

Strictly following national code guidelines and adhering to local jurisdiction requirements and variances, Symmetry products are ADA and ASME compliant and manufactured to meet the end users' specific needs. Symmetry Elevating Solutions representatives possess a wealth of knowledge and experience and are committed to excellence for the life of the product—before, during and after project completion.

With dealer locations spanning North America, we are equipped to meet the accessibility needs of a wide spectrum of clients, from home and business owners, to schools, municipalities and other governmental entities.

Please note that this guide is for planning purposes only, applies exclusively to national code and should not be used for construction. Prior to construction, please contact your local Symmetry Elevating Solutions representative and request a job-specific set of plans to ensure that you obtain the accurate dimensions and requirements for your project.

Your representative will also assist you to identify resources to ensure that your project plans will comply with the applicable state and local codes and the permitting authorities.

What is a Casket Lift?

The Symmetry Casket Lift is a Vertical Reciprocating Conveyor (VRC) designed and built to meet or exceed the requirements of ASME B20.1, *Safety Standard for Conveyors and Related Equipment*. **Not rated for passengers or riders**, these lifts will permit the operator to safely transport caskets and other mortuary equipment vertically from one level to another.

Design Considerations

When designing a space for a casket lift there are several factors that will impact the application. Below is a list of things to consider prior to proceeding.

Cargo Size and Weight

- What is the largest size casket that will ride on the lift?
- Will the desired platform size accommodate the cargo being moved?
- How much will the cargo weigh?
- What is the available footprint?

Loading

- How wide and tall does the opening at each landing need to be to safely load and unload the carrier?
- The carrier will be loaded from how many sides?
 - Only one side (enter/exit same side)
 - Two sides (straight-through opening or 90° opening)
 - Three sides
- For a smooth transition from the lowest landing finished floor to the platform surface a pit will be required. If a pit cannot be provided:
 - A ramp will be used to access the carrier
 - Cargo will be lifted onto the carrier

Machine Space, Shaft Construction and Installation

- Remote mounted controller and Hydraulic Power Unit (HPU) should be located within 20 feet of the ram
- Will the VRC be installed in a fire-rated shaft?
- A support wall will be required
 - Certain forces will be applied to the anchoring structure(s) with which the structure(s) must be capable of withstanding. Consultation of a structural professional is recommended (see page 14, Anchorage).
- A non-rated code compliant enclosure can be provided by the lift manufacturer
- Some components of the lift can be large and heavy (i.e. ram length and platform weight); consider how the parts will be lifted and maneuvered through the building and into the hoistway

Bracing

- Provided by lift manufacturer
- Provided by other

Guarding

- Non-operating sides of the lift must be guarded by an enclosure that is a minimum height of 8 feet tall. The material the enclosure is made of must reject a ¾" sphere.
- The operating sides of the lift must be guarded by a door or gate which are interlocked to the lift preventing the lift from moving if the door or gate is not in the closed and locked position.
 - Landing entrance door types
 - Fire-rated doors
 - Single swing gate
 - Double swing gate
 - Lift-up gate
 - Hatch cover (telescopic only)
 - Hatch door (telescopic only)
- Once the carrier has been loaded, the cargo will be contained by what method?
 - Snap chains
 - Drop bars
 - Collapsible gates

Power

- Recommended 240 VAC, 60 Hz, 1 phase
- Fused disconnect located within 10' of the controller

Operational Controls (not allowed to be accessible from the carrier - NO RIDERS)

- Constant pressure
- Momentary contact (automatic operation)
- Surface or flush mount
- NEMA considerations
 - The manufacturer of the VRC must be made aware of any other NEMA considerations

Finish Considerations

- Will the VRC be located indoor or outdoor?
- Will the VRC be in a corrosive or caustic environment?

Note: Although not prohibited, field welding is not anticipated during installation. Certain site conditions may cause situations where field welding of bracing may be considered a best practice. Any welding to the building structure must be approved by owner and/or architect or engineer. The lift structure should not require field welding.

Model 1320
Single mast VRC

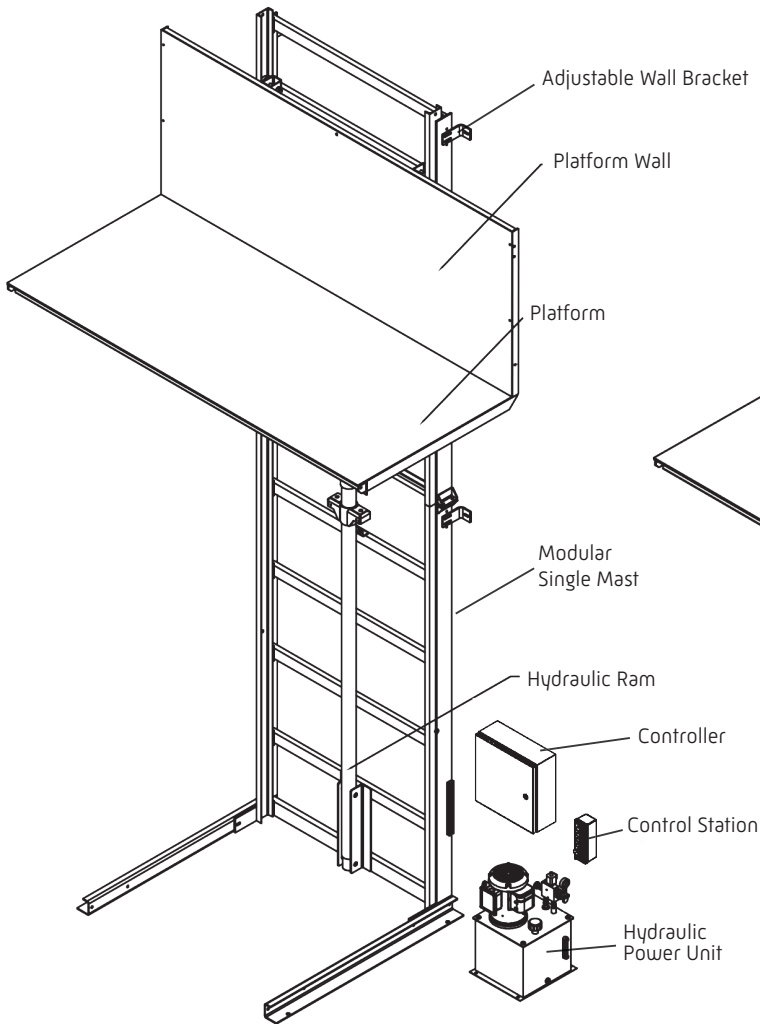

Model 1520
Telescopic mast VRC

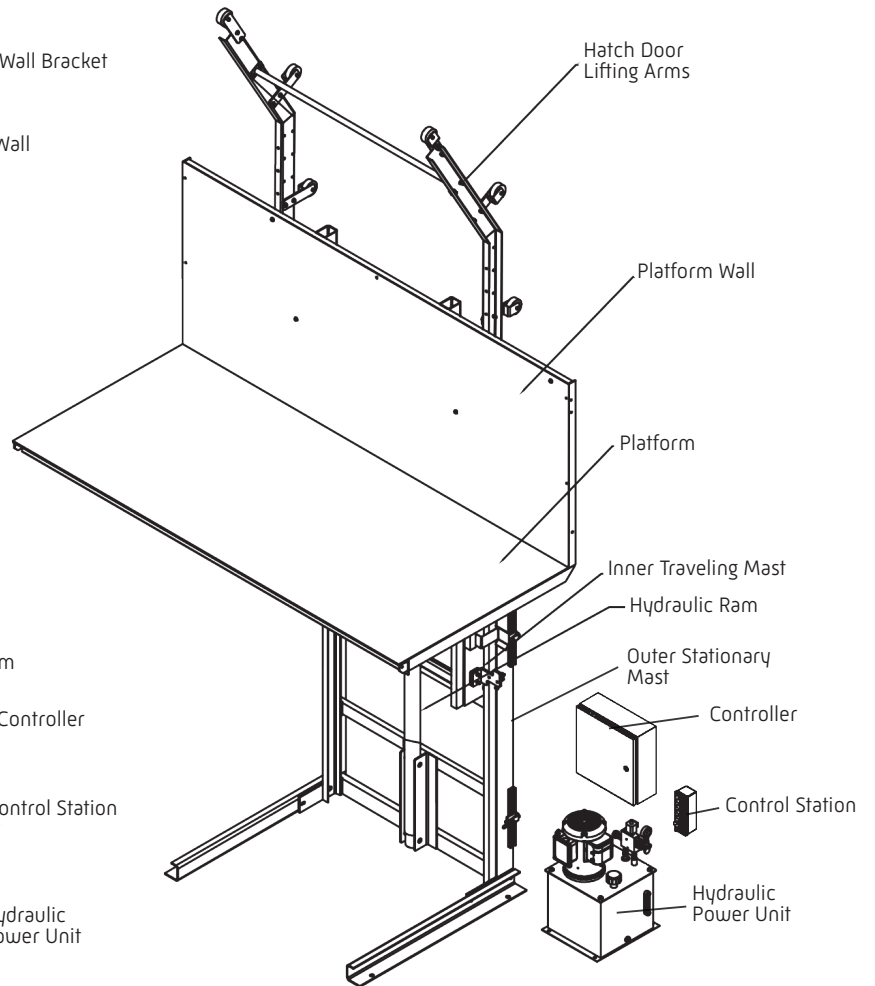

All VRCs must be enclosed by some means at the lower landing to prevent people or things from getting under the platform. The means of enclosure are either a shaftway enclosure built on site, or an enclosure provided by the manufacturer.

VRCs must be protected at the upper landing as well. When using a single mast, the upper landing will need to be protected by shaftway or enclosure. When using a telescopic mast, a hatch door, or hatch cover must be used to close the opening in the floor when the lift is at the lower landing.

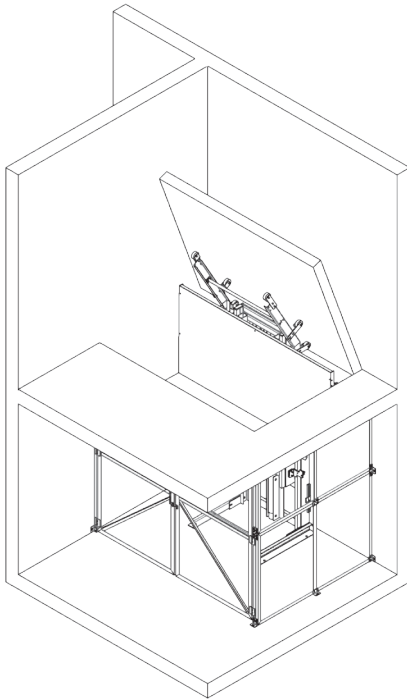

Hatch Door

When the lift is at the lower landing, the upper landing access opening is covered by a hatch door. The lift is controlled at the upper landing so the operator can visually verify there are no safety concerns as the lift rises. As the lift rises, arms attached to the carriage push the hatch door open. As the lift is lowered, the hatch door returns to its resting position. The hatch door must be designed to meet the relevant codes regarding floor loading.

Hatch Cover

When the lift is at the lower landing, the upper landing access opening is covered by a hatch cover. The lift is controlled at the upper landing so the operator can visually verify there are no safety concerns as the lift rises. As the lift rises, columns attached to the platform will lift the upper landing hatch cover. The hatch cover will return to its resting position when the lift is sent back down. The hatch cover must be designed to meet the relevant codes regarding floor loading.

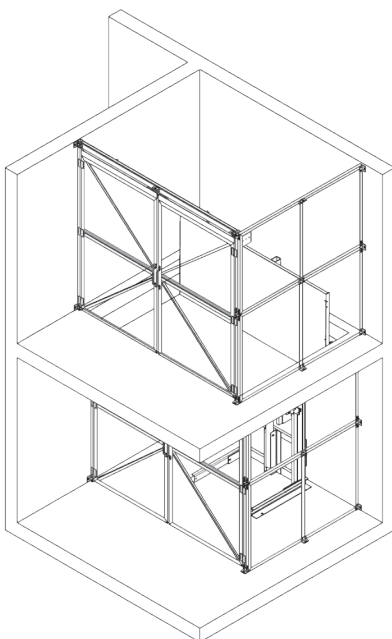
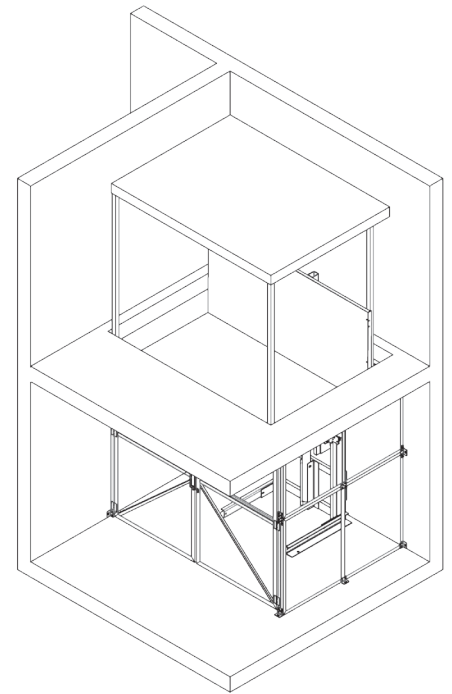

Enclosure

The lift must be enclosed at the lower landing to prevent people or things from getting under the platform when it is at the upper landing. In this design guide, the term "enclosure" is used to indicate an enclosure provided by the lift manufacturer, and the term "shaftway" is used to indicate an enclosure built on site by others. The illustration to the left shows a 2 sided enclosure at the upper and lower landings. A full height enclosure will extend from the lowest landing finished floor to 99½" above the upper landing. An enclosure at any given landing will be 99½" in height or the height of the ceiling minus ½".

Standard Features

- Rated Capacity: 750 to 1,000 lbs.
- Speed: 10-25 fpm
- Lifting Height: Up to 36' (minimum 20" between stops)
- Drive/Suspension: 2:1 Chain Hydraulic
- Stops: Two
- Steel construction with powder-coated finish
- Operation: Automatic for 1320 Single mast
- Operation: Constant pressure for 1520 Telescopic mast
- Controller: Remote
 - NEMA 1
 - Electrical disconnect by others
- TEFC motor
 - 1.15 service factor
 - 240 VAC, 60 Hz, 1 phase
- Modular design, no on-site welding required
- Safety/Warning label package
- Warranty: 5-year limited parts for structural components and 1-year for operational parts

Safety Features

- Overload relief valve
- Pressure gauge
- Emergency stop switch on control stations
- Landing interlocks keep doors closed and locked when platform is not at the landing
- Slack/Broken chain safety switch
- Velocity fuse
- Keyswitch on controls
- Slack/Broken chain safety device
- Manual lowering valve
- 48" tall platform walls on non-loading sides

Optional Features

- Power 208 VAC or 480 VAC
- 3 phase
- Mast guard
- Platform lighting
- Up to five stops
- Single mast (model 1320) or telescopic mast (model 1520)
- Non-skid platform surface (Black)
- Stationary ramp
- Moving platform audible signal
- Greater capacities available

Clear Platform Sizes

- 36", 42" or 48" width x 96" length

Enter/Exit Configurations

- Straight-Through
- 90°
- Same Side
- 3 Openings

Platform Access/Loading Guards

- Snap chains
- Drop bars

Upper and Lower Landing Access

- Single swing or double swing
 - Fire-rated door
 - Expanded metal gate
- Lift-up gate
- Upper landing (telescopic only)
 - Hatch door
 - Hatch cover



Mezzanine Application
(Enclosure/shaftway not shown for clarity)

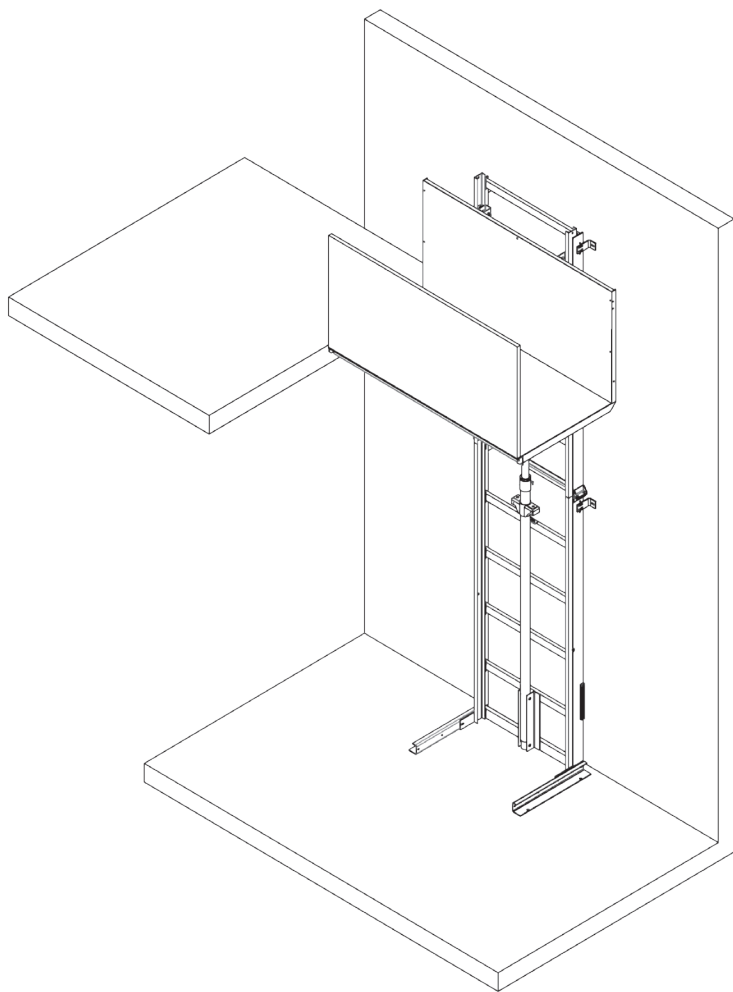

Mast anchored to a structural wall and foundation.
(ZP configuration shown)

Through the Floor Enclosure Application
(Enclosure/shaftway not shown for clarity)

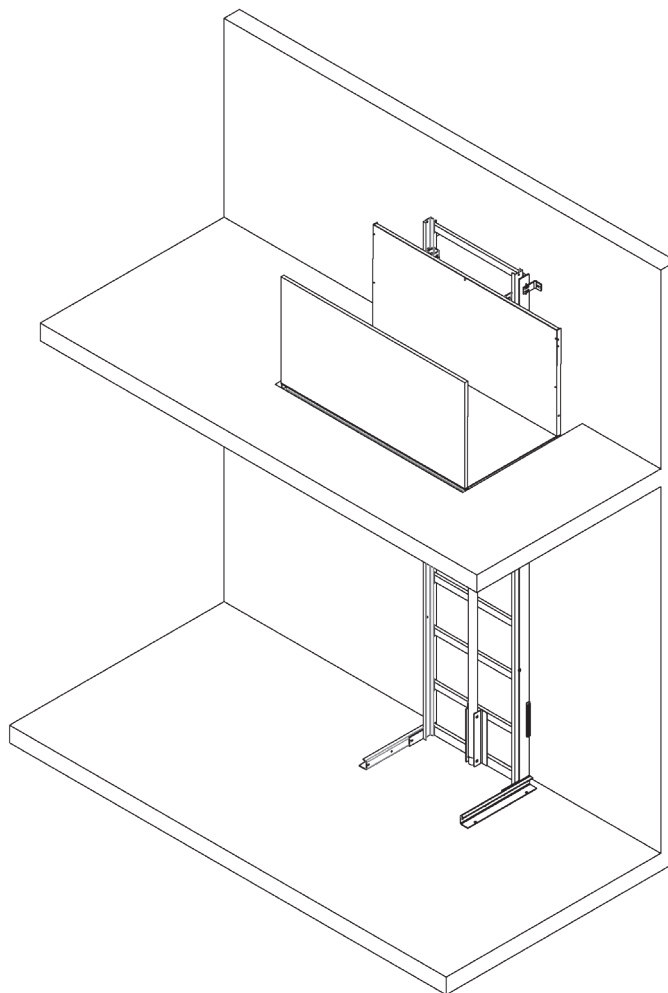

Mast anchored to a structural wall and foundation.
(ZP configuration shown)

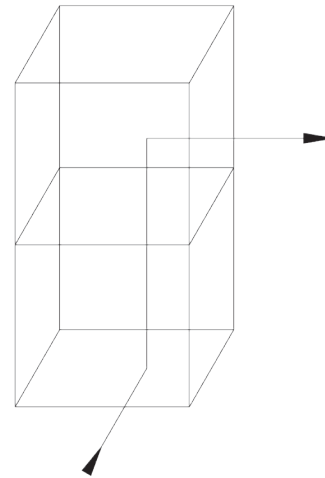
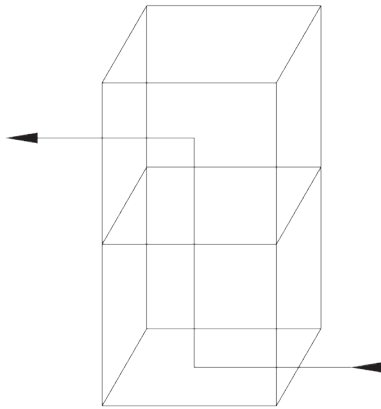

Straight-Through

90°

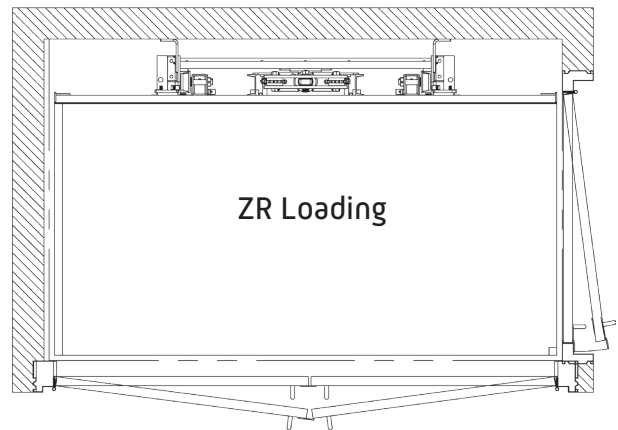
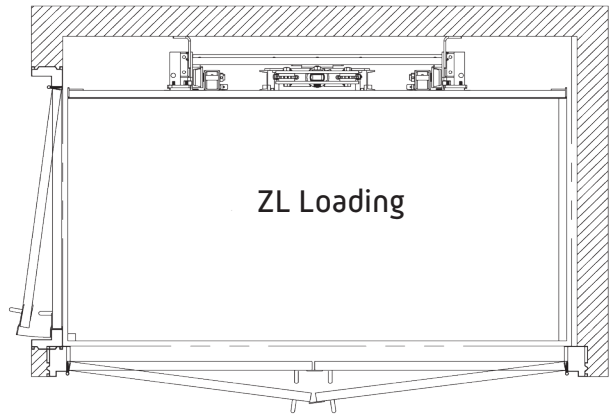
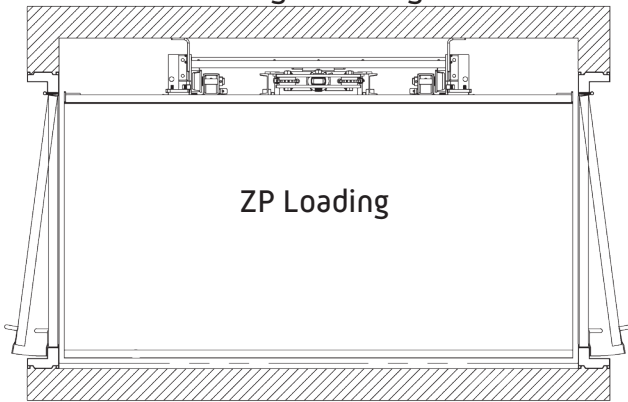

Loading Configurations

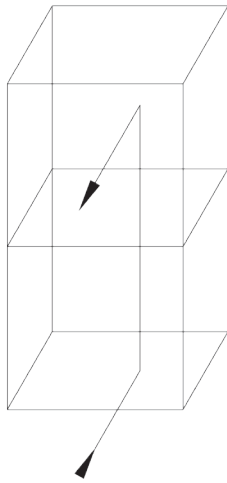

Enter/Exit Same Side

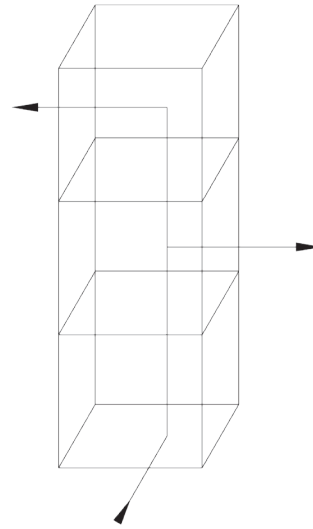

3 Opening

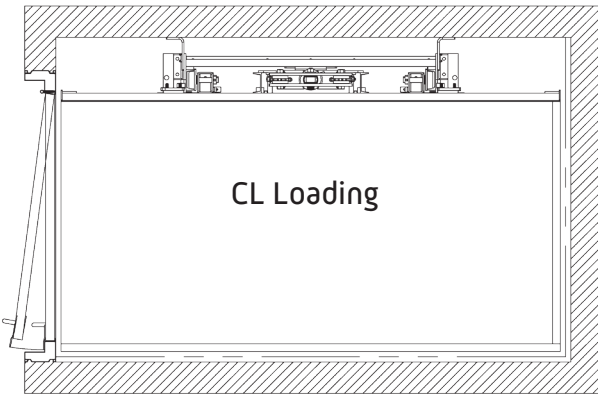

CL Loading

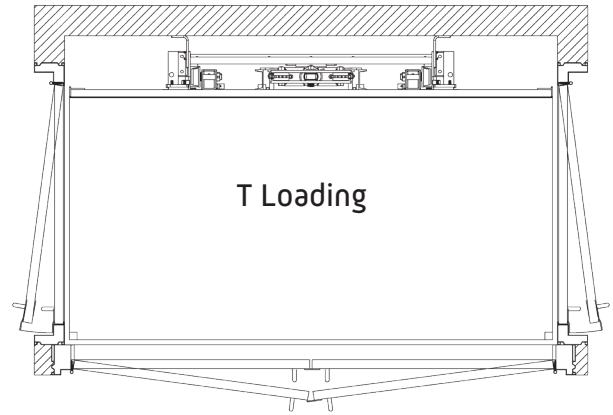

T Loading

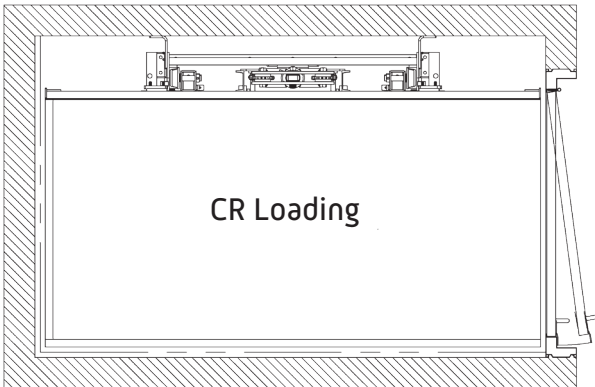

CR Loading

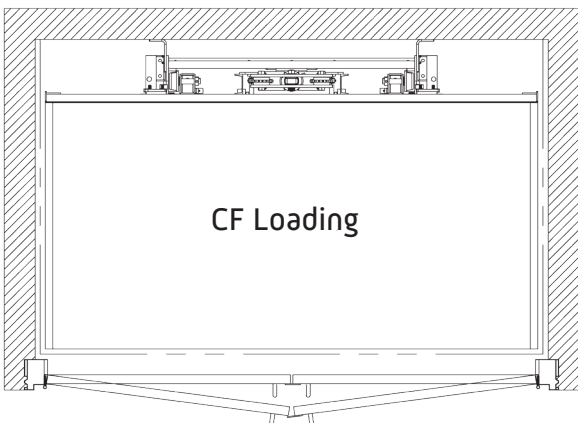

CF Loading

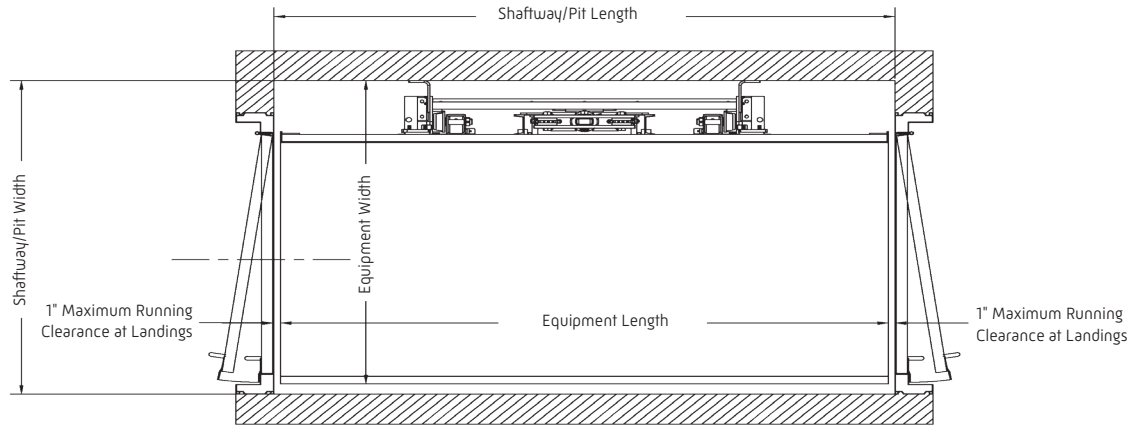

Shaftway Straight-Through Configuration [ZP Shown]

Nominal Platform Size [W" x L"]	Equipment Width [1]	Equipment Length	Shaftway/Pit Width [1]	Shaftway/Pit Length
36" x 96"	48 ³ / ₈ "	96"	50 ³ / ₈ "	98"
42" x 96"	54 ³ / ₈ "	96"	56 ³ / ₈ "	98"
48" x 96"	60 ³ / ₈ "	96"	62 ³ / ₈ "	98"

[1] The dimensions in the chart above are for single mast units only. If a telescopic mast is used, add 7¹/₈" to all width dimensions.

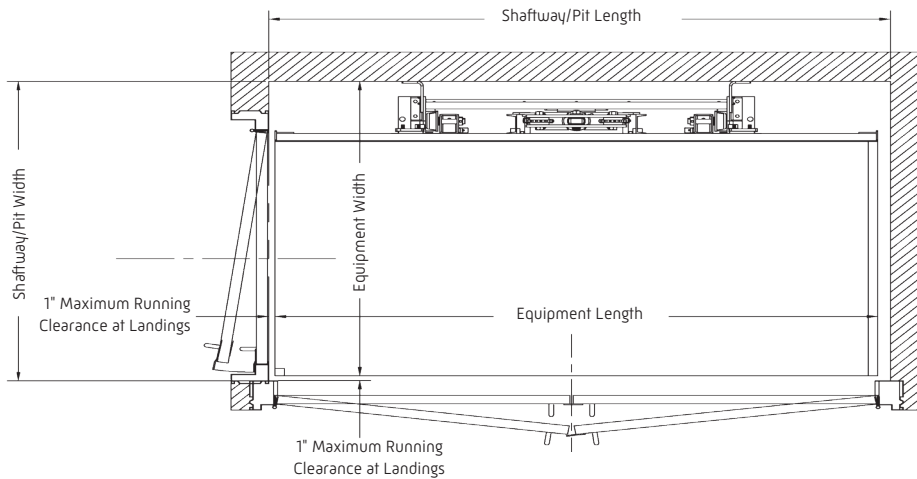

Shaftway 90° Configuration [ZL Shown; ZR Opposite]

Nominal Platform Size [W" x L"]	Equipment Width [1]	Equipment Length	Shaftway/Pit Width [1]	Shaftway/Pit Length
36" x 96"	48 ³ / ₈ "	96"	49 ³ / ₈ "	99"
42" x 96"	54 ³ / ₈ "	96"	55 ³ / ₈ "	99"
48" x 96"	60 ³ / ₈ "	96"	61 ³ / ₈ "	99"

[1] The dimensions in the chart above are for single mast units only. If a telescopic mast is used add 7¹/₈" to all width dimensions.

Minimum usable shaftway dimensions shown based on 1" running clearance at loading sides of the platform and 2" running clearance on non-loading sides. Shaftway may require larger dimensions and/or landing extensions to accommodate various safety devices and/or usable shaftway construction tolerances. Fire-rated doors shown, expanded metal doors may require larger shaftway dimension to allow for door interlocking devices.

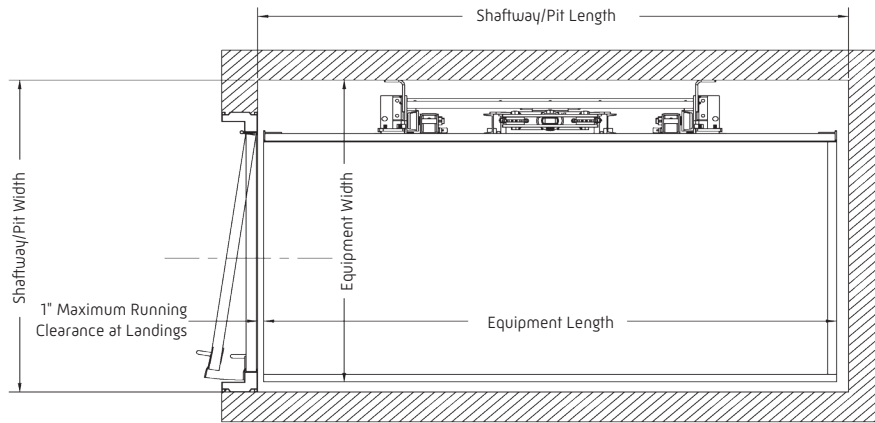

Shaftway Same Side Configuration (CL Shown; CR Opposite)

Nominal Platform Size (W" x L")	Equipment Width (1)	Equipment Length	Shaftway/Pit Width (1)	Shaftway/Pit Length
36" x 96"	48 ³ / ₈ "	96"	50 ³ / ₈ "	99"
42" x 96"	54 ³ / ₈ "	96"	56 ³ / ₈ "	99"
48" x 96"	60 ³ / ₈ "	96"	62 ³ / ₈ "	99"

(1) The dimensions in the chart above are for single mast units only. If a telescopic mast is used, add 7¹/₈" to all width dimensions.

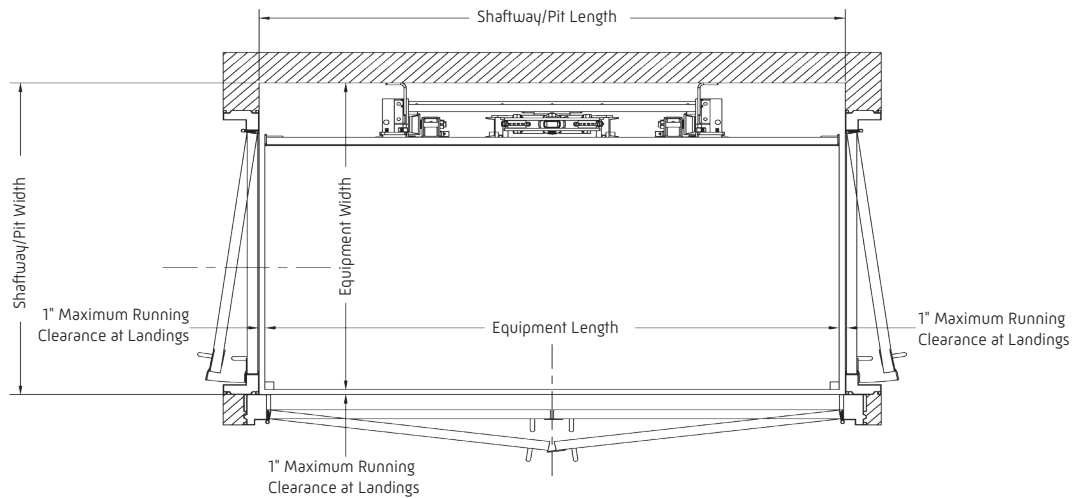

Shaftway 3 Opening Configuration (T Shown)

Nominal Platform Size (W" x L")	Equipment Width (1)	Equipment Length	Shaftway/Pit Width (1)	Shaftway/Pit Length
36" x 96"	48 ³ / ₈ "	96"	49 ³ / ₈ "	98"
42" x 96"	54 ³ / ₈ "	96"	55 ³ / ₈ "	98"
48" x 96"	60 ³ / ₈ "	96"	61 ³ / ₈ "	98"

(1) The dimensions in the chart above are for single mast units only. If a telescopic mast is used, add 7¹/₈" to all width dimensions.

Minimum shaftway usable dimensions shown based on 1" running clearance at loading sides of the platform and 2" running clearance on non-loading sides. Shaftway may require larger dimensions and/or landing extensions to accommodate various safety devices and/or shaftway construction tolerances. Fire-rated doors shown, expanded metal doors may require larger shaftway dimension to allow for door interlocking devices.

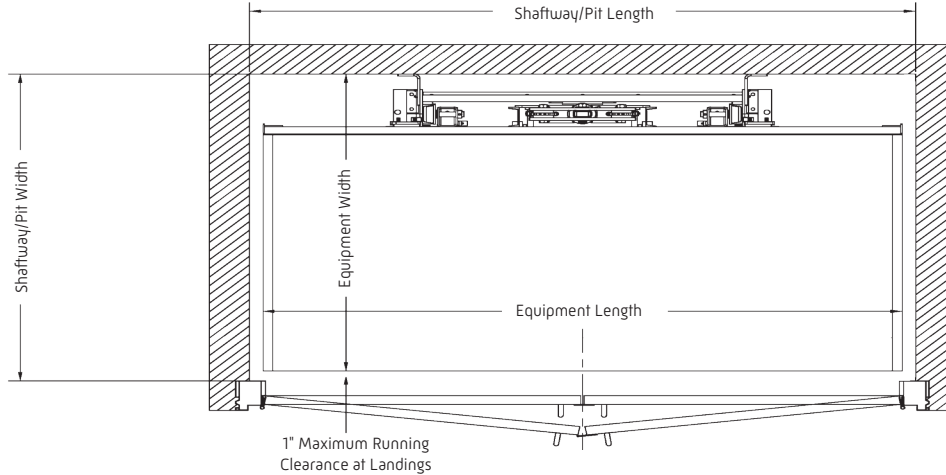

Shaftway Same Side Configuration (CF Shown)

Nominal Platform Size [W" x L"]	Equipment Width [1]	Equipment Length	Shaftway/Pit Width [1]	Shaftway/Pit Length
36" x 96"	48 ³ / ₈ "	96"	49 ³ / ₈ "	100"
42" x 96"	54 ³ / ₈ "	96"	56 ³ / ₈ "	100"
48" x 96"	60 ³ / ₈ "	96"	61 ³ / ₈ "	100"

[1] The dimensions in the chart above are for single mast units only. If a telescopic mast is used, add 7¹/₈" to all width dimensions.

Minimum usable shaftway dimensions shown based on 1" running clearance at loading sides of the platform and 2" running clearance on non-loading sides. Shaftway may require larger dimensions and/or landing extensions to accommodate various safety devices and/or usable shaftway construction tolerances. Fire-rated doors shown, expanded metal doors may require larger shaftway dimension to allow for door interlocking devices.

Enclosure Configurations

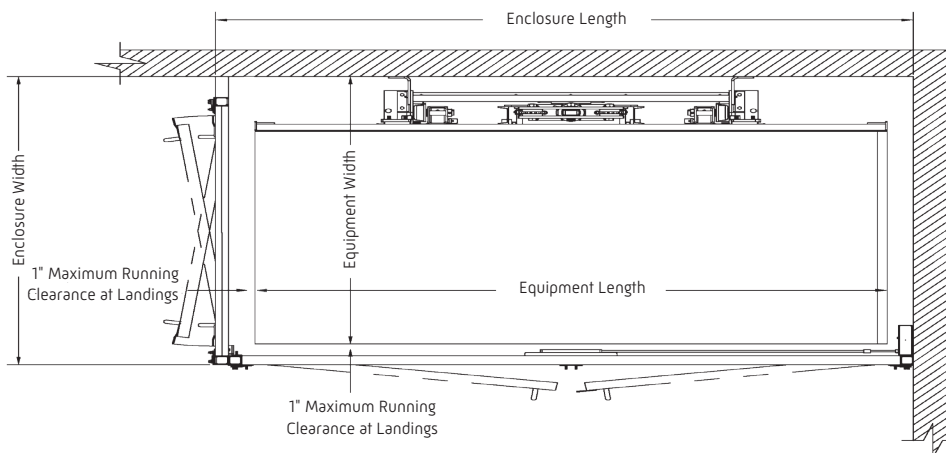

2-Sided Enclosure 90° Configuration (ZL Shown; ZR Opposite)

Nominal Platform Size [W" x L"]	Equipment Width [1]	Equipment Length	Enclosure Width [1]	Enclosure Length
36" x 96"	48 ³ / ₈ "	96"	53"	104"
42" x 96"	54 ³ / ₈ "	96"	59"	104"
48" x 96"	60 ³ / ₈ "	96"	65"	104"

[1] The dimensions in the chart above are for single mast units only. If a telescopic mast is used, add 7¹/₈" to all width dimensions.

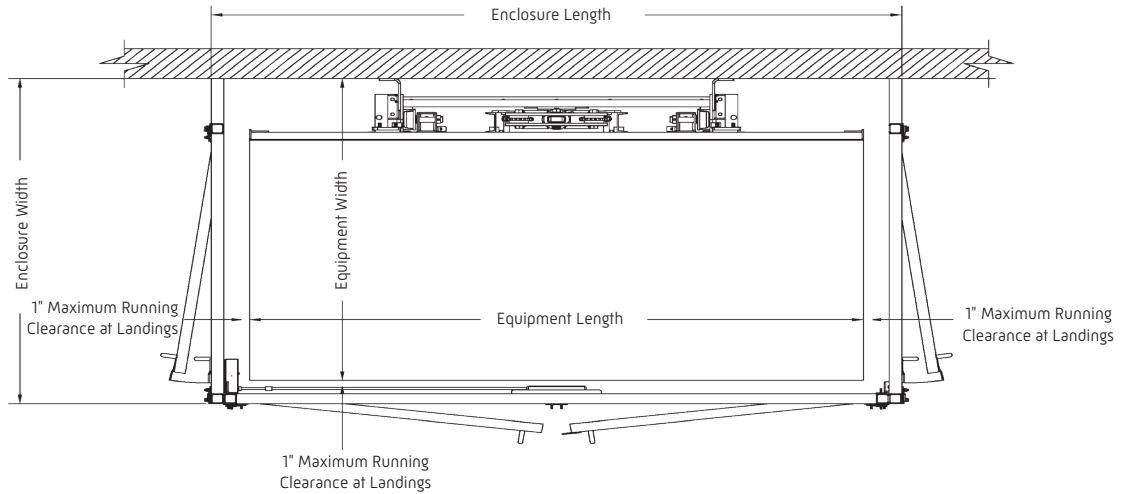

3-Sided Enclosure 3 Opening Configuration (T Shown)

Nominal Platform Size (W" x L")	Equipment Width (1)	Equipment Length	Enclosure Width (1)	Enclosure Length
36" x 96"	48 ³ / ₈ "	96"	53"	108"
42" x 96"	54 ³ / ₈ "	96"	59"	108"
48" x 96"	60 ³ / ₈ "	96"	65"	108"

(1) The dimensions in the chart above are for single mast units only. If a telescopic mast is used, add 7¹/₈" to all width dimensions.

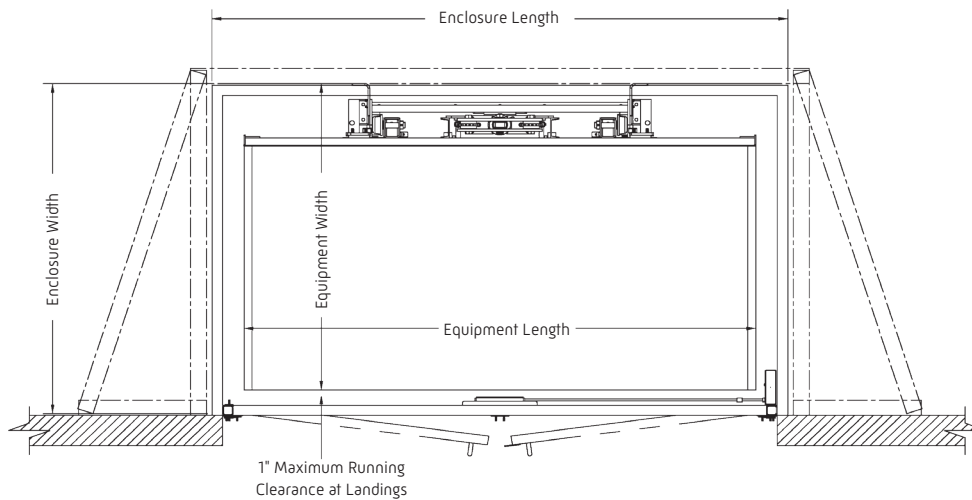

4-Sided Enclosure Same Side Configuration (CF Shown)

Nominal Platform Size (W" x L")	Equipment Width (1)	Equipment Length	Enclosure Width (1)	Enclosure Length
36" x 96"	48 ³ / ₈ "	96"	57"	108"
42" x 96"	54 ³ / ₈ "	96"	63"	108"
48" x 96"	60 ³ / ₈ "	96"	69"	108"

(1) The dimensions in the chart above are for single mast units only. If a telescopic mast is used, add 7¹/₈" to all width dimensions.

Wall axial bolt loading based upon multiple computer simulation with the platform traversing the entire unit travel, utilizing common recommended tieback locations with the capacity loading centered on the platform.

Transverse shear loading based upon edge loading of the platform with 1/2 of total load as a worst case and assuming that a single tieback location takes this entire moment load force.

Foundation shear loading based upon two foundation bolts sharing the normal joint reaction. Foundation axial area loading refers to the gravity weight of all components in combination with the capacity loading acting upon the foundation in the general contact areas of the lower vertical mass and the ram pivot.

All cited loading is individual bolt loading except the foundation area axial load.

All cited loading is static loading - appropriate factors of safety should be employed to cover dynamic loading conditions.

Important: Wall and foundation must be capable of supporting the imposed loads from the mast structure.

The information on this page is intended to provide the required anchorage forces to the structural engineer or architect so they can determine the best way to anchor the VRC to the building structure. This information is not intended to provide recommendations for the anchors or building support structure. If there is any uncertainty with the strength of the anchorage or building structure, then the installer must consult with the building structural engineer or architect to verify the anchorage and building structure are adequate to support the VRC loads listed.

Please note that this is a typical drawing. There may be more or less brackets than shown in this view.

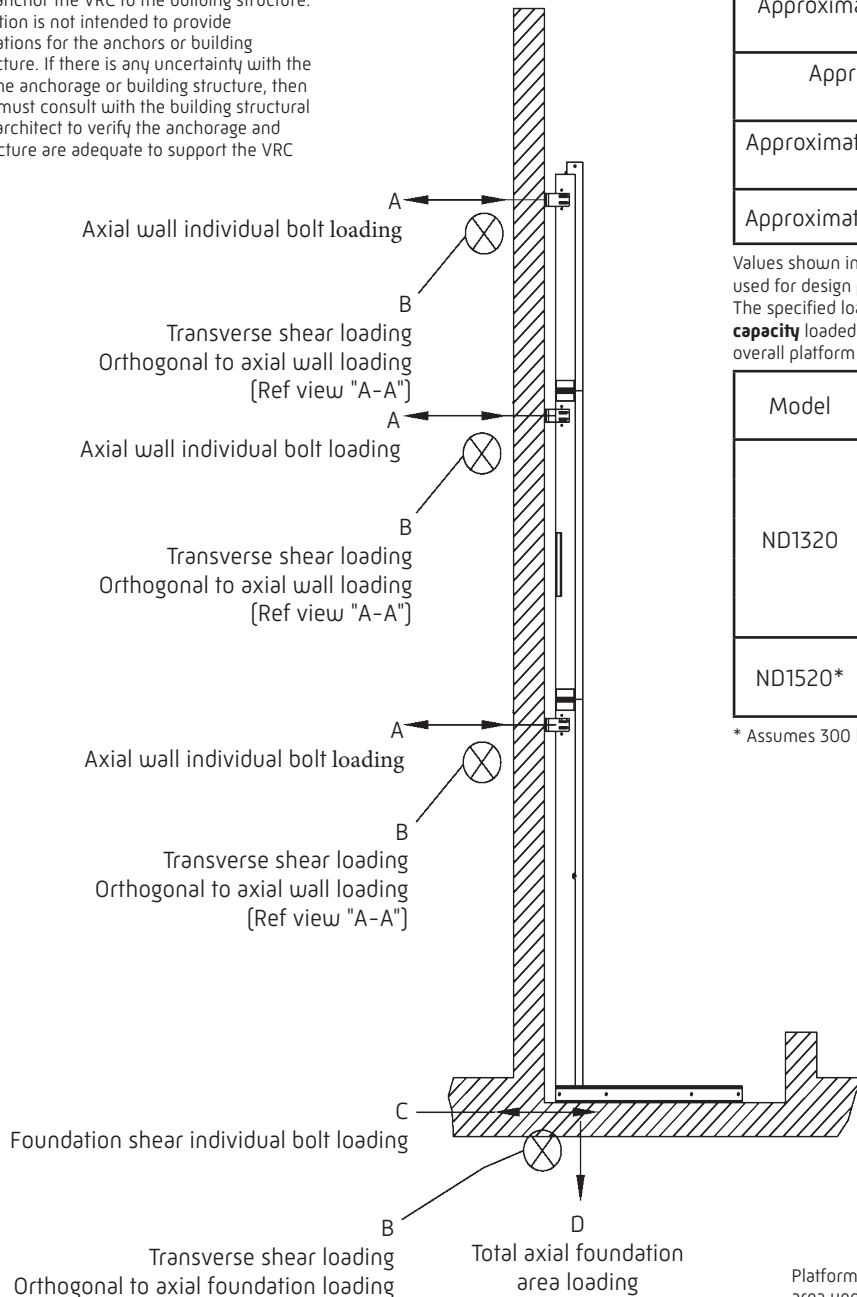

Load Information	
Approximate max individual wall anchor bolt axial loading	A
Approximate max wall anchor bolt transverse shear	B
Approximate max individual foundation anchor bolt shear loading	C
Approximate total foundation area axial loading	D

Values shown in this table are for general reference only and should not be used for design purposes. Refer to project specific drawings for design values. The specified loads are based on the worst case **load condition of 1,000 lb. capacity** loaded on the center of the platform, assuming a 48" x 96" overall platform size.

Model	Travel (in.)	A (lbs.)	B (lbs.)	C (lbs.)	D (lbs.)
ND1320	96	455	300	200	2990
	144	395	300	145	3329
	192	455	300	200	3546
	240	410	300	160	3790
	288	350	300	145	3997
ND1520*	96	520	490	190	3570
	120	445	490	150	3842

* Assumes 300 lbs. single swing hatch door

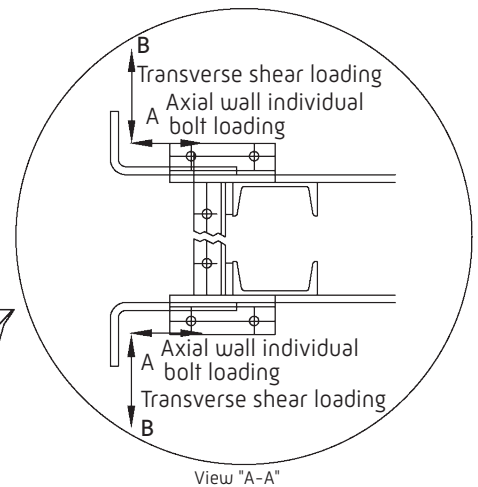

Platform and ram weight, along with the capacity loading concentrated in area under ram. Mast weight concentrated in areas under each mast. In a safety-set scenario, the entire axial foundation load, except for the ram weight, would be concentrated in areas under each mast.

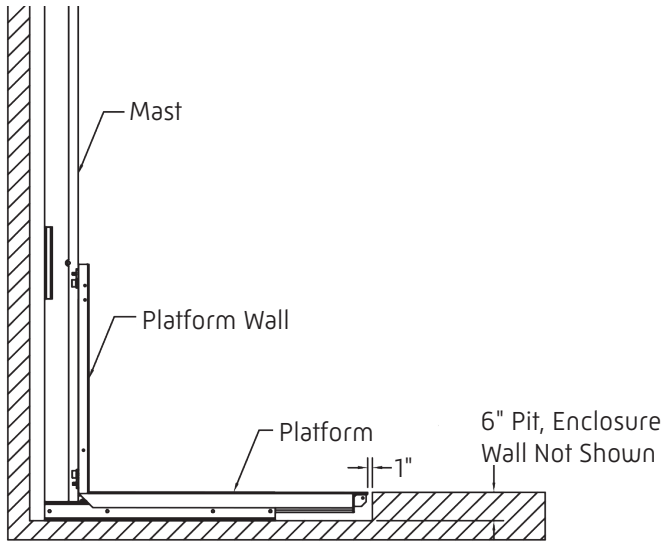

Pitted Application

A pitted application provides a smooth transition from the lower landing finished floor to the platform. A 6" pit is acceptable in most applications, an 8" pit will be required in some higher capacity applications.

Stationary Ramp Application

A stationary ramp application will allow for hand truck loading and unloading.

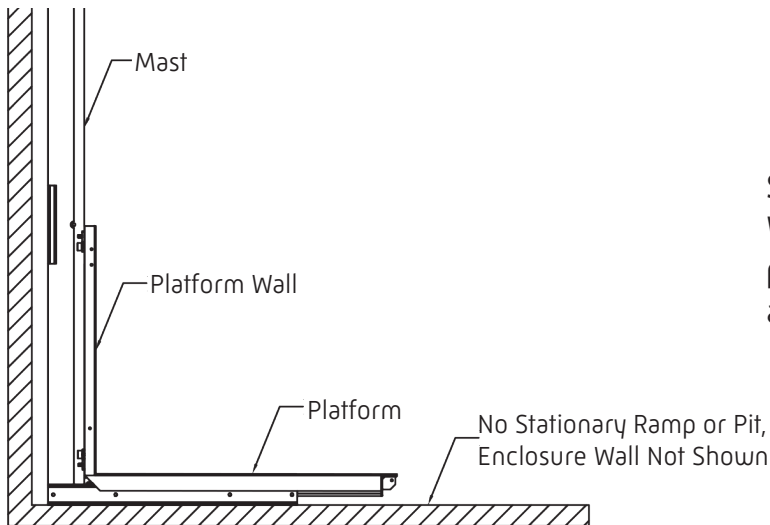
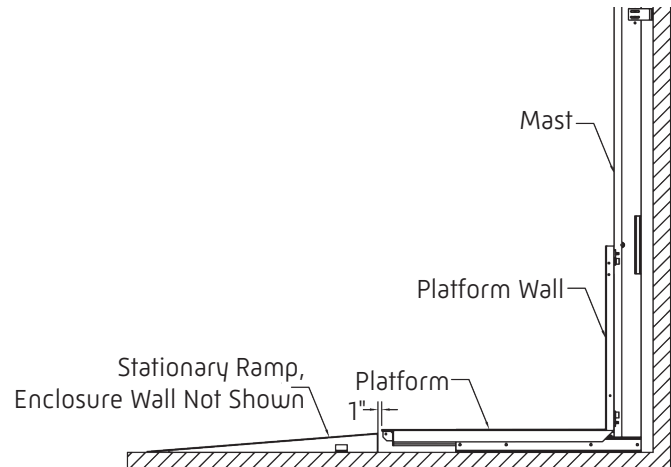

Surface Mounted Application

When installed without a pit or ramp the platform must be loaded manually or with a lifting device.

Upper Landing
Minimum Machine Overhead

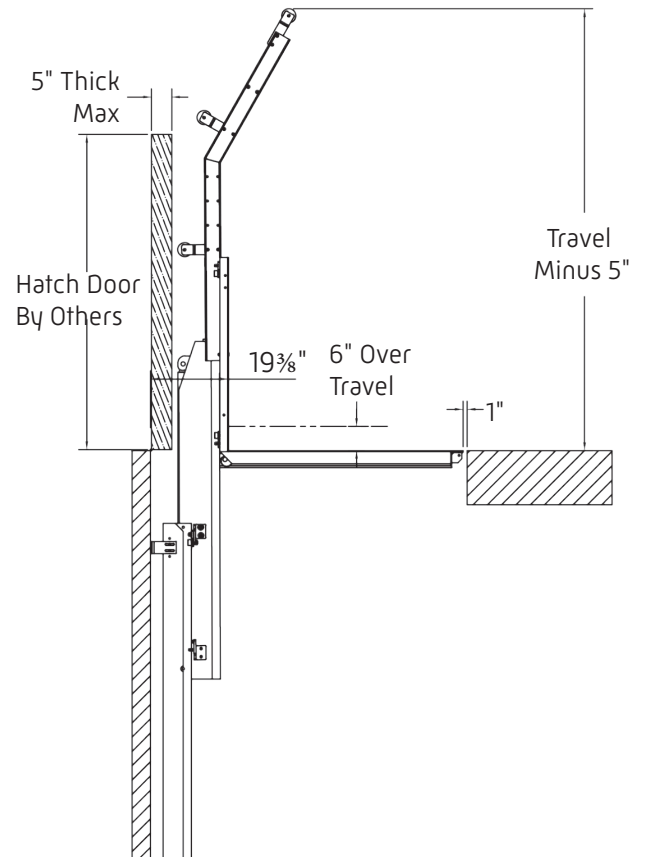
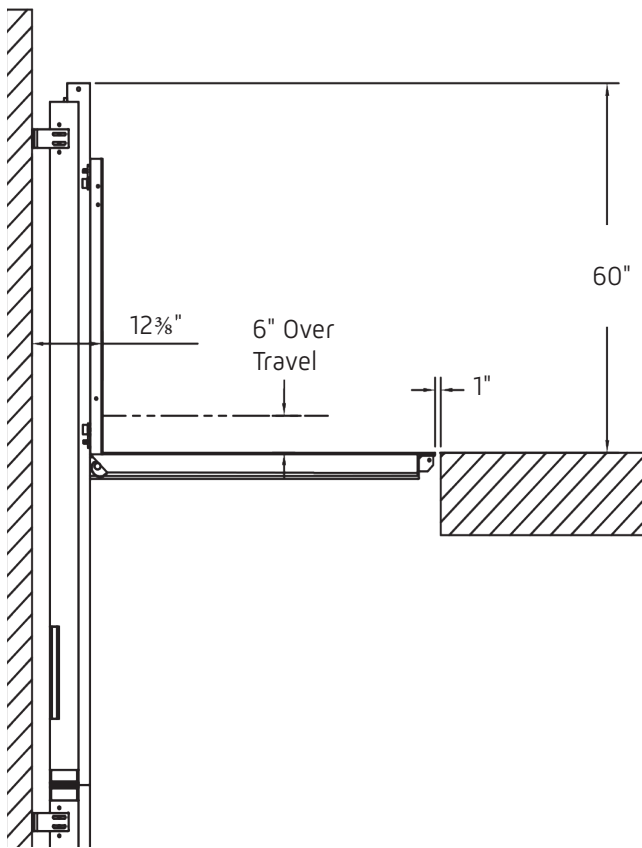

Standard Mast

- Mast will project a minimum of 60" above the upper landing.

Telescopic Mast

- Mast will be below the upper landing when the VRC is at the lower landing and will require the travel distance less 5" as a minimum overhead at the upper landing.



Double swing expanded metal gates (also available as single swing)



Double swing fire-rated doors



Single swing fire-rated door



Snap chains



Drop bars and snap chains

Hydraulic Power Unit (HPU)

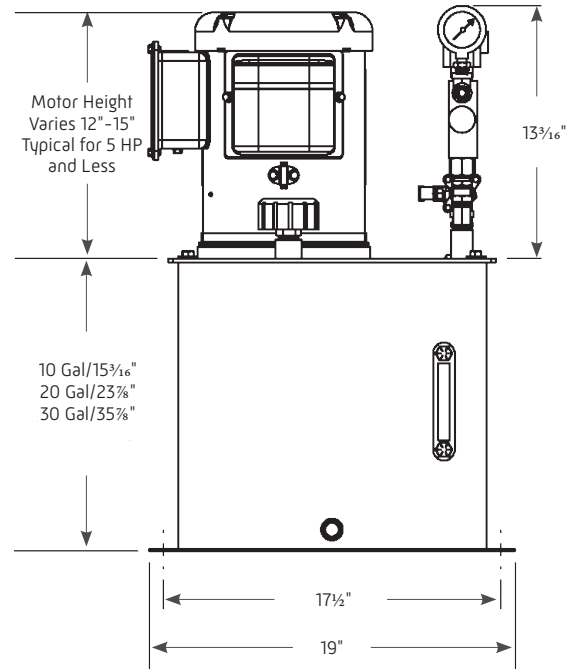
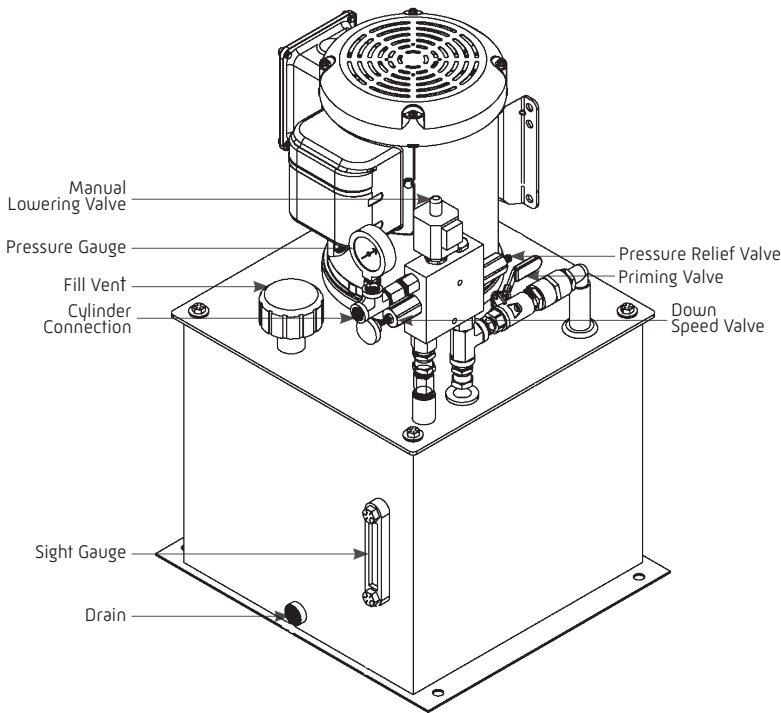

Notes:

- 1) The HPU should be located within 20 feet of the ram
- 2) Standard controller size 15³/₄" W x 15¹³/₁₆" L x 6⁷/₁₆" D
- 3) The control area temperature must be maintained between 50°F and 90°F
- 4) Job specific drawings will show HPU capacity and dimensions

Control Stations

Standard Control Station

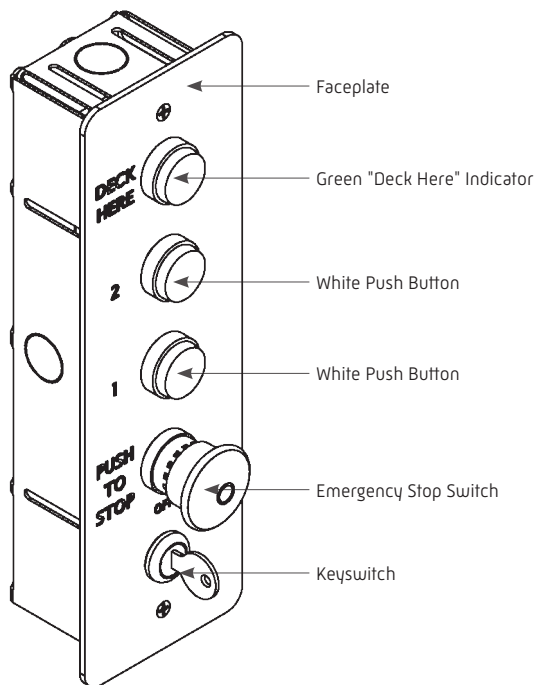

NEMA Control Station

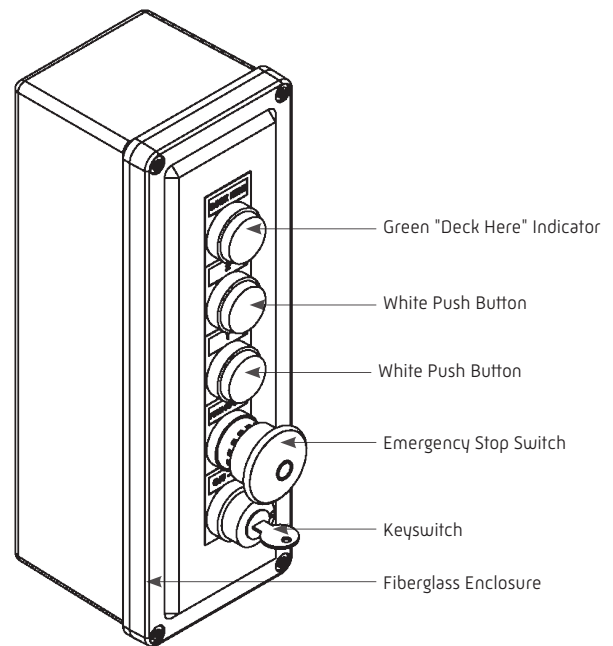



Providing Innovative and Creative Designs for Today's Material Handling Needs

Symmetry VRC Advantages:

- Made in the U.S.A. 
- Custom designed to your specific application
- Up to a 6,000 lb. capacity
- Factory assembled and tested prior to shipment
- Modular design, no on-site welding required